

Performance of Ds-Cdma System With Qam Over Awgn Multipath Fading Channel

Makode Tushar S.¹, Bansode Rahul S.²

¹(Student Of Department E&TC ,SPCOE / Savitribai Phule Pune University, Pune)

²(Assistant Professor Of Department E&TC ,SPCOE / Savitribai Phule Pune University, Pune)

Abstract: In this paper we review the work to amend the quality or reducing the efficacious Bit Error Rate (BER) in a multipath fading channel. Higher Signal to noise ratio implies a reduced BER and vice versa as BER is inversely proportional to SNR. The study focuses on improving the performance of digital communication system. For reliable communication, the BER should be as low as possible i.e. amelioration in BER. Rake receiver a special type of receiver consisting of multiple correlators, which multiplies the received signal by time-shifted versions of a local code sequence which increases the Signal to Noise Ratio SNR and decreases the BER. Here BER performance of AWGN and Rayleigh fading channel are differentiated for 16-QAM and Simulated using Gold Code as carrier for Multipath using Rake receiver also BER Performance comparison for (QPSK, 16-QAM, 64-QAM, 256-QAM) AWGN and Rayleigh fading channel is done. The simulation is carried out with MATLAB. BER improvement of DS- CDMA system with QAM using baseband modulations for AWGN channel is discussed.

Keyword :-BER, DS-CDMA, Fading, Multipath Fading Channels, SNR, QAM Rake Receiver

I. Introduction

As wireless communication becomes an ecumenical communication standard for transferring the data, the main challenge is to transfer the information with efficiency and reliability as possible through the inhibited bandwidth [1]. The signal reaches the receiver through various propagation paths. Transmitted signals pull off at the receiver via a direct path known as Line of Sight (LOS) or through multiple paths by the scattering, reflection, and diffraction of surrounding things such as buildings, trees or other obstacles so a received signal is necessarily addition of multiple components irrespective of main component and each of which travelled mutually a diverse path from the transmitter. As a result of which each multipath component gets delayed depending on its path length. Delayed multipath components results in Inter-Symbol Interference (ISI) and it inflicts limit on the equivalent data rate that the channel can support. Another major problem encountered by multipath channel is fading. [6]. Multipath fading occurs as widespread multipath components approach with varied phases and at any of the points in free space, the components cancel each other, causing deep fades in the received signal level. When concurrent multiple communications are carried out in the multipath environment, the interference Caused from various directions will also surge respectively. This multipath propagation brings about the signal, present at the receiver side to distort and fade significantly, which reduces the Signal to Noise Ratio (SNR) and thus results in higher Bit Error Rate (BER) [5]. BER is used to check the performance of wireless communication system which ensures reliable communication.

The principle of spread spectrum communication implies that the bandwidth occupancy is much higher than usual. A larger bandwidth results in lower power spectral density, in the channel the signal just looks like noise CDMA is a popular and eminent technology in cellular system due to its higher performance and capacity. It is based on Direct-Sequence Spread Spectrum modulation so it is called as DS-CDMA system. Here large number of users can transmit data simultaneously over a same channel [6]. The DS-CDMA transmitter multiplies each user's data signal by a particular and specific code waveform and its detector receives a signal which is the inclusion of the sum of all users' signals, which overlapping in frequency and time. In a traditional DS-CDMA system, a specific user's signal is recognize by correlating the whole received signal with the same user's code waveform. Judging the number of paths at the receiver end is a difficult and also allocating them the number of correlators becomes more challenging [4]. The performance and capacity of the DS-CDMA system is limited by another factor called Multiple Access Interference (MAI).[6]. Signals in a wireless telecommunication system, travel from transmitter to respective receiver over multiple reflective paths this phenomenon is said to be multipath propagation [1]. The distortion of signals caused by multipath propagation is known as fading. Fading in a wireless communication system, causes the signal to be received with multiple numbers having deep fade also the received power is less than noise power hence performance of wireless system becomes poor resulting in a greater BER [1].

II. Direct Sequence-Code Division Multiple Access System

Spread spectrum technique is a method of transmission, where the signal occupies a bandwidth in excess amount of the minimum required to transfer the information the band spread is covered by means of a code which is not dependent of the data and the reception of signals is synchronized with the same code used at the receiver for de-spreading and subsequent recovery of data [4].

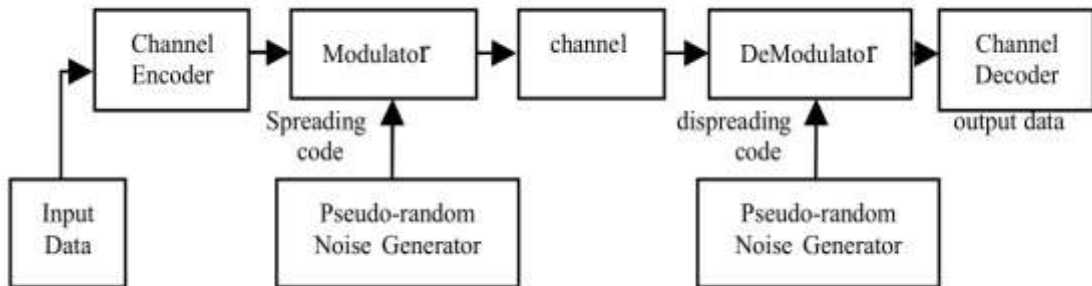

Fig -1: General implementation model of the DS-SS communications system

The spread spectrum signals are usually used for the applications such as: Obtaining message privacy in the presence of other listeners. Transmitting a signal with low power and Makes it difficult for an unknown user to detect it in presence of background noise. The DS-SS method is one of the most well-known forms of spreading technique. This is due to the simplicity and effectiveness by which direct sequencing can be implemented.

Fig.1. shows the basic model of DS-SS communication system. The pseudo-random noise generator block provides a spreading code which is also called as the pseudo-noise (PN) code sequence. Every bit of the original input data is directly modulated with the PN sequence and is represented by multiple bits in the transmitted signal. The input data can be successfully recovered only when the same PN sequence is used at the receiving side, to demodulate the spread spectrum [5]. The Transmission bandwidth is directly proportional to the of number of the bits that are used for the PN sequence, at the transmitter side. A data sequence of 7-bit spreads the signal across a frequency band which is seven times greater than one-bit code sequence or it is said to have a processing gain of seven. One of the key features of the spread spectrum modulation technique is its ability to avoid pass band noise which improves the coverage range for transmitter power. The sliding correlator proves to be advantageous by eliminating the synchronization of the PN sequence. Sensitivity adjustment can be done by changing the sliding factor and the correlator filter bandwidth. The inherent processing gain of the spread spectrum results in less processing gain than the direct pulse system.

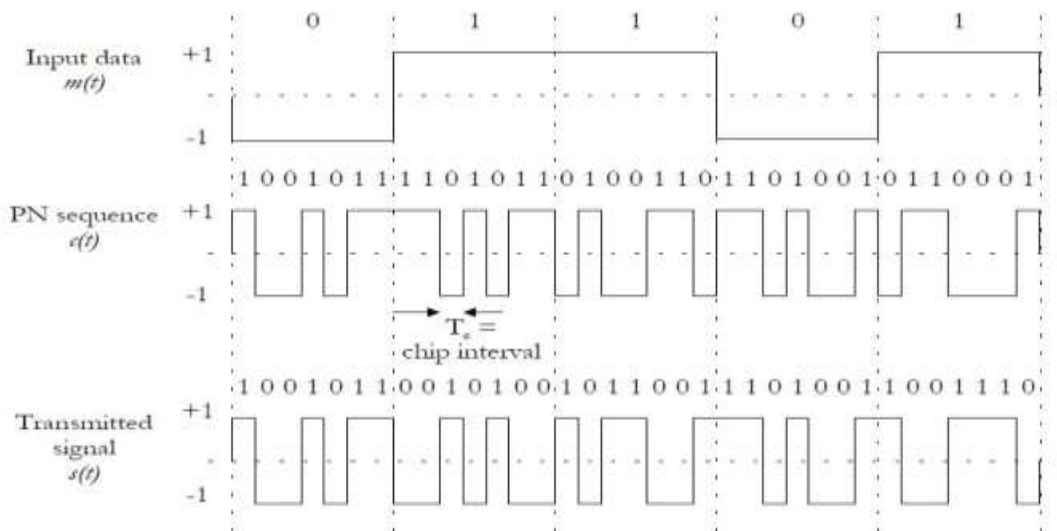

Fig -2: Generation of a DS-SS signal by using an exclusive-OR (XOR) operation.

An input data bit of zero results in a PN sequence the code bits of which are to be transmitted without inversion, and given input data bit of one inverts the coding bits. Rather than representing the binary data with bits 0's and 1's, the given input signal and PN sequence both are converted into a bipolar waveform having their respective amplitude levels of ± 1 .

In CDMA systems, all users transmit the data with the same bandwidth simultaneously and the communication systems which follows this concept are said to be a "spread spectrum systems" therefore in this transmission method, the frequency spectrum of a code-signal is spread by using a code uncorrelated with that same signal so in a result we get more bandwidth occupancy. The codes that are used for spreading, that have minimum cross-correlation values which are unique to each and every user. [4].

Direct sequence signals are generated by modulating a carrier signal with a code sequence in a DS-CDMA system the incoming information data is digitized if it is not in a digital format, modulo-2 is added to a higher speed code sequence. The combination of information and code together are used to modulate an RF carrier by using QAM modulation method. As the modulating function is dominated by high speed code, it finds the RF signal bandwidth giving rise to the spread spectrum signal [3].

III. Multipath Propagation And Fading

Fading is a distortion which is experienced by a modulated telecommunication signal over a propagation media. In any wireless communication system, fading is caused due to multipath propagation which is also called as multipath induced fading. Multipath in wireless telecommunication system, is the propagation concept that results in radio signals' coming to the receiving antenna by two or more paths. Multipath fading is caused by factors like refraction, reflection and diffraction of a signal from Buildings Mountains and scattering by small objects. The distortion of the various signals caused by multipath is said to be as fading or in the real world as the multipath causes constructive and destructive interference and also phase shifting of the signal so the multipath of signal occurs if there is more than one path for transmission of a radio signal. The phenomenon of diffraction, reflection and scattering all are there reasons for additional radio propagation paths that are apart from the direct optical LOS path in between the transmitter and receiver [10].

IV. Fading Channels

A Fading Channel is nothing but a communication channel which has endure various fading phenomenon's during transmission of the signal [9]. Although in real world application, the radio propagation effects add together and multipath is generated by the same fading channels due to multiple signal propagation paths, due to these multiple signals the actual received signal at the receiver is the vector sum of the all the received signals [3]. These signals may be incident from direction with different angle of arrival. Therefore in multipath fading, some signals add the direct path while some others subtract the direct path. In a wireless communication channel, the signal which is transmitted from transmitter can go from transmitter to receiver over multiple reflective paths and giving rise to multipath fading which causes fluctuations in phase, angle of arrival and amplitude of the received signal [9]. The data signal which is transmitted from the BTS (Base Transceiver Station) suffers multiple reflections from the nearby buildings, and other obstacles in their way before coming to it's mobile station. Such multipath fading channels are generally divided into slow fading channels, fast fading and channels or frequency-selective or flat fading channels.

V. Types Of Fading Channels

5.1 Rayleigh Fading Channel

The Rayleigh fading is primarily occurred due to multipath reception of signals [4]. This is used to simulate an environment which has multiple scatters of signal and not a single Line of Sight (LOS) path. But if there are sufficient multiple scatters in the environment, then all the reflected signals which are appearing at the receiver side becomes uncorrelated in amplitude level with mean being equal to zero and phase is evenly distributed between the limit of 0 to 2π .

5.2 Rician Fading Channel

The Rician fading channel is same as that of Rayleigh fading channel, except in Rician fading, a strong main domin component is there which a stationary (non fading) signal is and it is generally said to be the LOS (Line of Sight) Component. Consider about two Gaussian random variables that are A and B. Here A models the specular component (LOS) and B models the random component. By definition, model A has non-zero mean (m), B has zero mean and they both have same variance σ^2 . Then the transformation $Z=(I^2 + Q^2)^{1/2}$ is Rician Distributed for BPSK. The ratio of power of specular component to that of power of random component is said to be Rician factor 'k' and it is defined as $k=m/2\sigma^2$.

VI. Rake Receiver

In a DS-CDMA delayed reflections interfering with the direct signal in multipath channel, can be detected by using a special type of receiver called RAKE which uses several baseband correlators to individually process the multipath components. Improved communications reliability and performance can be achieved by the use of combination of correlators. RAKE receiver, can combine multipath components, which are deferred variant of the original signal transmission. Due to reflections of the signal from obstacles a radio channel can consist of several replicas of originally transmitted signals having different amplitudes, phases, and delays, a RAKE receiver can be used to resolve and combine them. This combining is done so that the signal to noise ratio (SNR) is improved at the receiver. RAKE receiver provides a separate correlation receiver for each multipath signals, so the the time shifted versions of the original signal can be collected. The RAKE receiver contains several correlators within this received signals are multiplied by time shifted variants of a locally generated code sequence. This separates signals such that individual finger only attain signals coming in over a path which is resolvable. The spreading code preferential should have a very small autocorrelation value for any non-zero time offset in order to avoid crosstalk between fingers.[8]

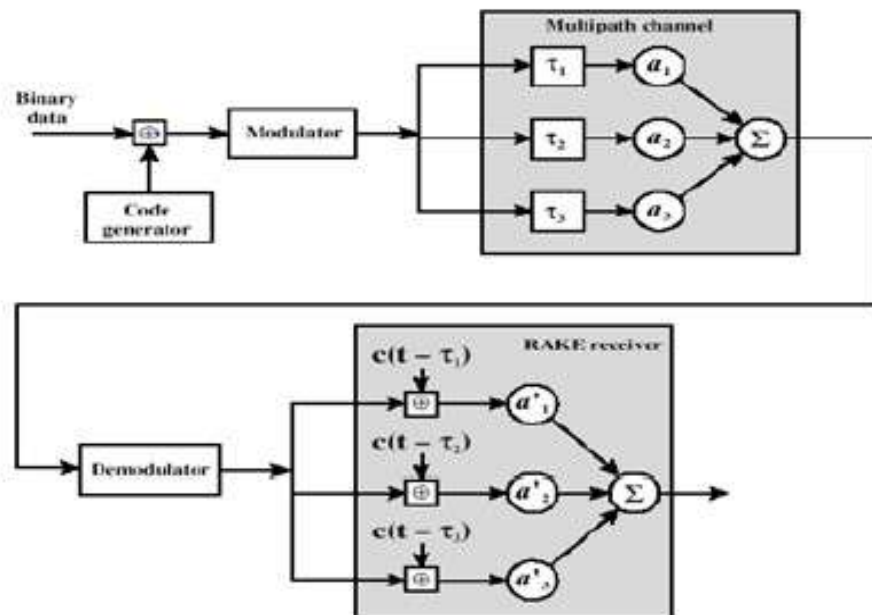

Fig -5: Block diagram of RAKE Receiver

VII. Qam Modulation

7.1 16-Quadrature Amplitude Modulation

Within QAM the encoding of the information into a carrier wave succeeded by variation of the amplitude of both the carrier wave and 'quadrature' carrier that is 90° out of phase with the main carrier in which is accordance with two input signals. That means, the amplitude and the phase of the carrier wave are simultaneously changed according to the information transmitted. 16 state Quadrature Amplitude Modulation (16-QAM), contain four I values and four Q values. As a result of which there are total 16 possible states for the signal. It can transition from one to another state at any symbol time. As $16 = 2^4$, four bits per symbol can be sent. This consists of two bits for I and two bits for Q for which the symbol rate is one fourth of the bit rate. So this modulation format produces a more spectrally efficient transmission. 16- QAM is more efficient than BPSK, QPSK or 8PSK. Note that QPSK is the same as 4-QAM [10].

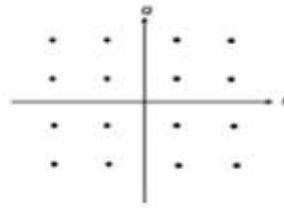

Fig – 16-QAM Constellation

7.2 64-Quadrature Amplitude Modulation

Within QAM the encoding of the intelligence into a carrier wave is succeeded by variation of the amplitude of both the carrier wave and ‘quadrature’ carrier that is 90° out of phase with the main carrier in which is accordance with two input signals. That means, the amplitude and the phase of the carrier wave are consecutively changed according to the information transmitted. 16 state Quadrature Amplitude Modulation (16-QAM), show up four I values and four Q values. As a result of which there are total 16 possible states for the signal. It can transition from one to another state at any symbol time. As $16 = 2^4$, four bits per symbol can be sent. This consists of two bits for I and two bits for Q for which the symbol rate is one fourth of the bit rate. So this modulation format produces a more spectrally efficient transmission. 16- QAM is more efficient than BPSK, QPSK or 8PSK. Note that QPSK is the same as 4-QAM [10].

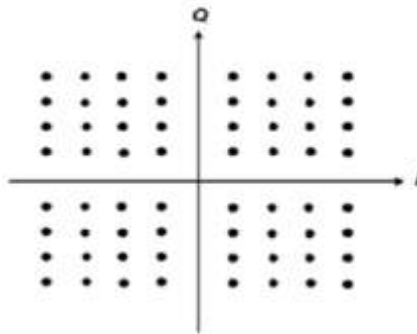
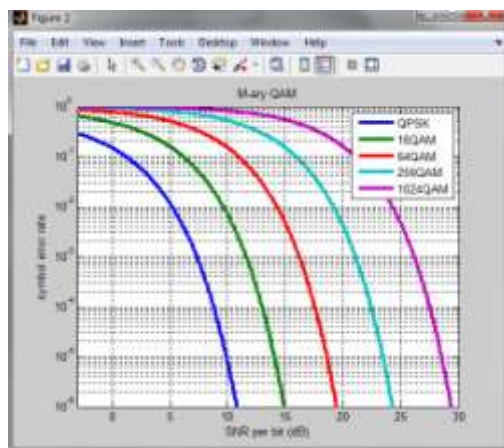

Fig -7: Constellation Diagram for 64-QAM

VIII. Simulation Results



Graph -1: BER Vs SNR for Various QAM in AWGN Channel

Graph 1 displayed that the BER performance of QPSK and different QAM like 16 – QAM, 64- QAM, 256- QAM, and 1024-QAM in AWGN fading channel. It show, QPSK superior performance than QAM in AWGN channel, while 16 - QAM gives greater BER performance than other QAM signals

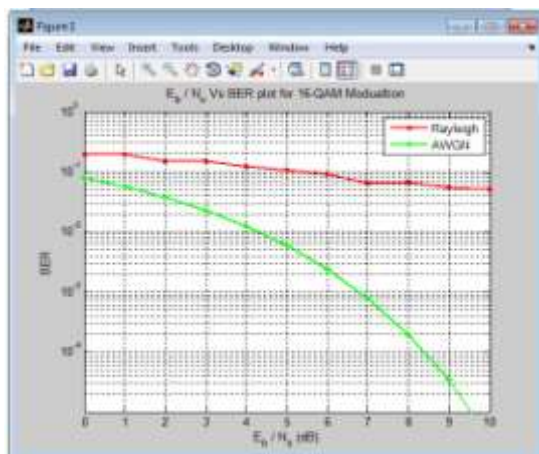

Graph -2: Comparison of Rayleigh and AWGN Channel for 16-QAM

Graph 2 shows the BER performance comparison of AWGN and Rayleigh fading channel for 16 QAM . It can be observed that performance of AWGN is better than Rayleigh fading channel for 16 QAM signal.

IX. Conclusion

The performance of AWGN channel is found greater as compared to Rayleigh fading channel for QAM Modulation. As far as QAM modulation is concerned it is observed that 16 QAM gives better performance than other QAM schemes for AWGN channel whereas 64 QAM gives better performance for Rayleigh fading channel correlated to o QAM schemes. As number of path increases, BER also increases which affect the performance of communication system. For 16 QAM AWGN channel gives better performance than Rayleigh fading channel. The effective error rate in multipath fading channel is significantly reduced by the use of Rake receiver. Adding multiuser degrade the performance of system. BER increases as number of user increases, it has been observed due to adding user causes interference which is distributed (share) among existing users equally and SNR decreases slightly.

Reference

- [1]. J.G.Proakis, "Digital Communications", New York: McGraw Hills.
- [2]. Theodore S. Rappaport, "Wireless communications principles and practice", Prentice Hall, New Jersey.
- [3]. J.Ravindrababu, E.V.Krishnarao, "Performance comparison of spreading codes in linear multi user detectors for DSSSS-CDMA system", WSEAS transactions on communication, ISSN 2224-2864, Issue 2, Volume 12, Feb. 2013.
- [4]. G.A.Bhalerao, R.G.Zope, "BER improvement of DS- CDMA with Rake receiver using multipath fading channel", International Conference on Recent Trends in engineering & Technology -2013(ICRTET'2013) Special Issue of International Journal of Electronics, Communication & Soft Computing Science & Engineering, ISSN: 2277-9477.
- [5]. SafinaShokeen, "Bit Error Rate (BER) analysis of Rayleigh Fading channels in mobile communication", 'International Journal of Advance Research in Science and Engineering IJARSE', Jan.2013, Vol. No.2, IssueNo.1, ISSN-2319-8354.
- [6]. Athar Ravish Khan, "Performance evaluation of DS-CDMA using MATLAB", 'International Journal of Advances in Engineering & Technology', Jan 2012, ISSN-22231-1963.
- [7]. SuchitaVarade, Kishore Kulat, "BER comparison of Rayleigh fading, Rician fading and AWGN channel using chaotic communication based MIMO-OFDM system", 'International Journal of Soft Computing and Engineering', (IJSCE) ISSN 2231-2307, volume- 1, Issue-6, Jan-2012.
- [8]. N.AnandRatnesh, K.Balaji, "Performance analysis of DSSSS-CDMA rake receiver over AWGN channel for wireless communications," 'International Journal of Modern Engineering Research (IJMER)', May-June 2012, Vol.2, Issue.3, pp-859-863.
- [9]. J.Rajesh, "Design of multiuser CDMA system in fading channels", 'IJCTA', Sept-Oct 2011.
- [10]. A. SudhirBabu, "Evaluation of BER for AWGN, Rayleigh and Rician fading channels under various modulation Schemes", 'International Journal of Computer Applications', (0975 -professor 8887), Volume 26- No.9, July-2011.
- [11]. N.B.Kanirkar, J.N.Sarvaiya, "BER Vs SNR performance comparison of DSSSS-CDMA FPGA based hardware with AWGN, spreading codes and code modulation techniques", 'International Journal of Electronic Engineering Research', ISSN 0975-6450, Vol. 1, No. 2 2009, pp 155-168.